

TKP35 series

Robust all-rounder
with variable inner distribution



Trademarks are legally protected for the TSUBAKI KABELSCHLEPP GmbH
as a national or international registration in the following countries:
tsubaki-kabelschlepp.com/Trademarks

Subject to change.

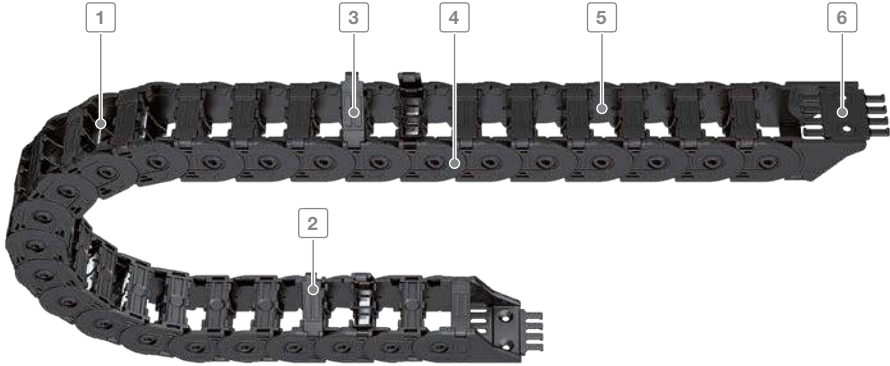

Inner heights



Inner widths



tsubaki-kabelschlepp.com/
tkp35

- 1 Dividers and height partitions for cable separation
- 2 Designs with inward or outward opening crossbars
- 3 Easy and quick to open at any position
- 4 Integrated noise damping
- 5 Interior space is gentle on the cables without sharp edges
- 6 End connectors with optional strain relief

Features

- Robust and extremely rigid stroke system
- Quiet operation due to internal dampening system
- Weight-optimized cable carrier geometry
- Interior without sharp edges, design that protects the cable
- Variable inner distribution
- Vertical moveable dividers or with arresting cams, can be attached at 2-mm increments (not B; 16)
- Easy-to-open versions, left or right (not B; 16)
- Quick and easy to open
- Optional strain relief can be fully integrated into the end connector



Reliable cable separation through fixable dividers



Design 030 with outside opening and detachable crossbars on both sides



Design 040 with inside opening and detachable crossbars on both sides



Optimised utilisation of the interior space; vertical and horizontal inner distribution possible

Type	Opening variant	Stay variant	h_i [mm]	h_G [mm]	B_i [mm]	B_k [mm]	B_i - grid [mm]	t [mm]	KR [mm]	Additional load ≤ [kg/m]	Cable- d _{max} [mm]
TKP35											
		030	32	40	16 – 50	26 – 62	–	35	48 – 125	2	25
		040	32	40	25 – 50	37 – 62	–	35	48 – 125	2	25

**Technical manual**

Would you like more information on the TKP35 series?
Our technical manual with all information on configuring your cable carrier can be found at tsubaki-kabelschlepp.com/download.

TKP35 series | Overview

TKP35 series

Unsupported arrangement			Gliding arrangement			Inner distribution				Installation variants			Page
Travel length \leq [m]	$v_{max} \leq$ [m/s]	$a_{max} \leq$ [m/s ²]	Travel length \leq [m]	$v_{max} \leq$ [m/s]	$a_{max} \leq$ [m/s ²]	TS0	TS1	TS2	TS3	vertical hanging or standing	lying on the side	rotating arrangement	
2.3	5	20	–	–	–	•	•	–	–	•	•	•	182
2.3	5	20	–	–	–	•	•	–	–	•	•	•	183

Inner heights



Inner widths



[tsubaki-kabelschlepp.com/](http://tsubaki-kabelschlepp.com/tkp35)
tkp35

TKP35

Key for abbreviations
on page 16

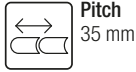

Pitch
35 mm



Inner height
32 mm



Inner widths
16 – 50 mm



Bending radii
48 – 125 mm

Stay variants



Design 030 page 182

Frame with outside opening crossbars on both sides

- Weight-optimised plastic frame with particularly high torsional rigidity.
- Can be opened at any position on both sides.
- **Outside:** opening and detachable crossbars.



Design 040 page 183

Frame with inside opening crossbars on both sides

- Weight optimised plastic frame with high torsional rigidity.
- Can be opened at any position on both sides.
- **Inside:** opening and detachable crossbars.

Design guidelines
from page 62

Technical support:
technik@kabelschlepp.de

Unsupported arrangement

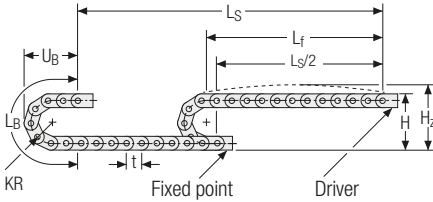

KR [mm]	H [mm]	H _z [mm]	L _B [mm]	U _B [mm]
48	146	176	220	103
60	170	200	258	115
75	200	230	306	130
100	250	280	384	155
125	300	330	463	180

Inner heights



Inner widths



Load diagram for unsupported length depending on the additional load.

Sagging of the cable carrier is technically permitted for extended travel lengths, depending on the specific application.

Intrinsic cable carrier weight $q_k = 0.5 \text{ kg/m}$ with $B_i 16 \text{ mm}$. For other inner widths, the maximum additional load changes.

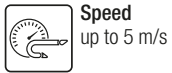
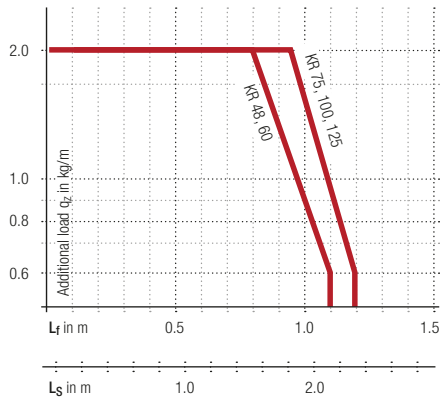

tsubaki-kabelschlepp.com/
tkp35



TRAXLINE® cables for cable carriers

Hi-flex electric cables which were specially developed, optimised and tested for use in cable carriers can be found at traxline.de.

Additional product information online



Installation instructions, etc.:
Additional information via your smartphone or online at tsubaki-kabelschlepp.com/support



Configure your cable carrier here:
online-engineer.de

Stay variant 030 – with outside opening and detachable crossbars

- Weight-optimised plastic frame with particularly high torsional rigidity.
- Can be opened at any position on both sides.
- **Outside:** opening and detachable crossbars.



Key for abbreviations on page 16



Stay arrangement on each chain link (**VS: fully-stayed**)



B_i 16 – 50 mm

Design guidelines from page 62

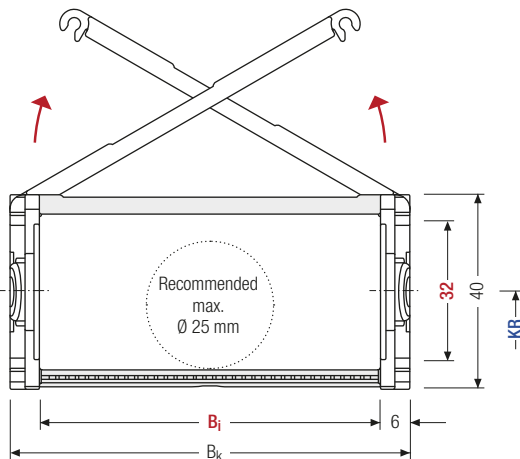

The maximum cable diameter strongly depends on the bending radius and the desired cable type. Please contact us.

Calculating the cable carrier length

Cable carrier length L_k

$$L_k \approx \frac{L_S}{2} + L_B$$

Cable carrier length L_k rounded to pitch t

Technical support: technik@kabelschlepp.de

h_i [mm]	h_G [mm]	B_i [mm]				B_k [mm]	KR [mm]					q_k [kg/m]
32	40	16	25	38	50	$B_i + 12^*$	48	60	75	100	125	0.5 – 0.8

*For B_i 16 = $B_i + 10$

Order example



TKP35
Type

030
Stay variant

50
 B_i [mm]

100
 KR [mm]

700
 L_k [mm]

VS
Stay arrangement

Stay variant 040 – with inside opening and detachable crossbars

- Weight-optimised plastic frame with particularly high torsional rigidity.
- Can be opened at any position on both sides.
- **Inside:** opening and detachable crossbars.



Inner heights



Inner widths



Stay arrangement on each chain link (**VS: fully-stayed**)



B_i 25 – 50 mm

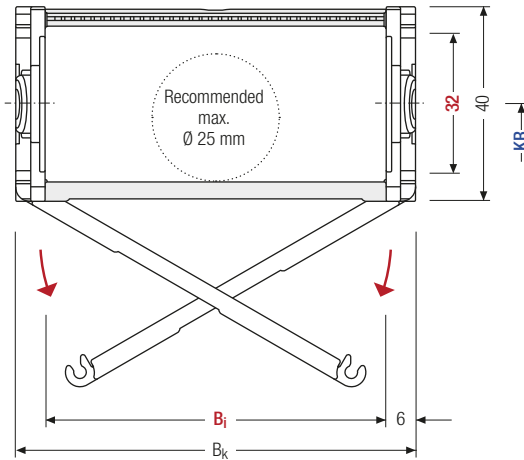

The maximum cable diameter strongly depends on the bending radius and the desired cable type. Please contact us.

Calculating the cable carrier length

Cable carrier length L_k

$$L_k \approx \frac{L_S}{2} + L_B$$

Cable carrier length L_k rounded to pitch t

h_i [mm]	h_G [mm]	B_i [mm]			B_k [mm]	KR [mm]					q_k [kg/m]
32	40	25	38	50	$B_i + 12$	48	60	75	100	125	0.6 – 0.8

Order example



TKP35 Type	·	040 Stay variant	·	50 B_i [mm]	·	100 KR [mm]	·	700 L_k [mm]	·	VS Stay arrangement
---------------	---	---------------------	---	------------------	---	----------------	---	-------------------	---	------------------------

Divider systems

The divider system is mounted on every 2nd chain link as a standard.

As a standard, dividers or the complete divider system (dividers with height separations) are movable in the cross section (**version A**).

For applications with lateral accelerations and applications with the cable carrier rotated by 90°, the dividers can easily be fixed on the stay through rotation.

The arresting cams snap into the catch profiles in the covers (**version B**).

Key for abbreviations on page 16

Design guidelines from page 62

Technical support: technik@kabelschlepp.de

Divider system TSO without height separation

Vers.	a _T min [mm]	a _x min [mm]	a _c min [mm]	a _x grid [mm]	n _T min
A	3	6	4	—	—
B	4.5* / 5	6	4	2	—

* Only B₁ 25

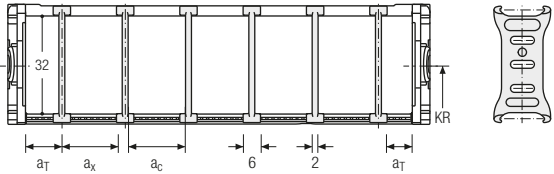

Divider system TS1 with continuous height separation

Vers.	a _T min [mm]	a _x min [mm]	a _c min [mm]	a _x grid [mm]	n _T min
A	3	6	4	—	2
B	4.5* / 5	6	4	2	2

* Only B₁ 25

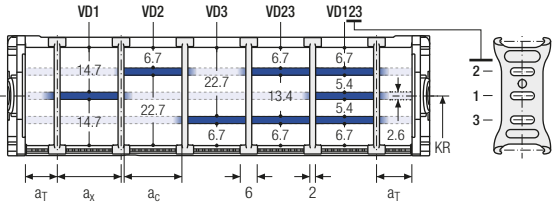

The dividers can be moved in the cross section.

Order example



TS1	.	A	.	3	-	VD1
						⋮
						VD3

Divider system Version n_T Height separation

Please state the designation of the divider system (**TS0**, **TS1**, ...), the version, and the number of dividers per cross section [n_T].

When using divider systems with height separation (**TS1**), please additionally state the position (e.g. VD1) viewed from the left driver belt. You are welcome to add a sketch to your order.

TKP35 | End connectors

TKP35 series

Single-part end connectors – plastic

(suitable for B_i 16)

The plastic end connectors can be **connected from above or below**. The connection type can be changed by altering the position of the end connector.

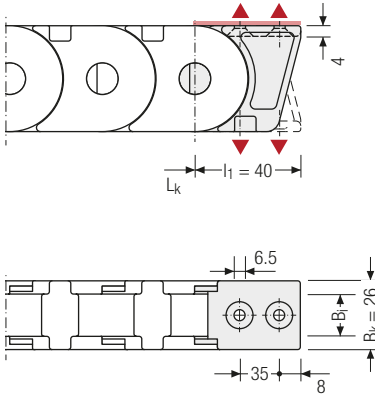

Single-part end connectors – plastic

(suitable for B_i 25 – 50)

The plastic end connectors can be **connected from above or below**. The connection type can be changed by altering the position of the end connector.

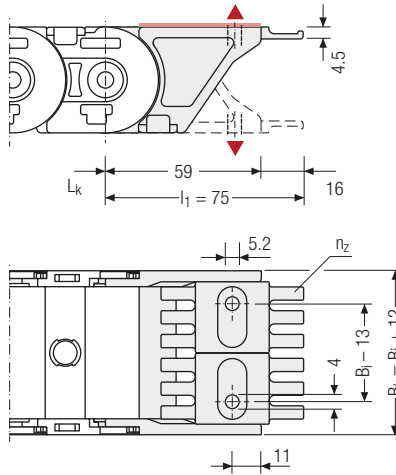

▲ Assembly options



The end connectors are optionally also available without strain relief comb.

B_i [mm]	B_{EF} [mm]	n_z
25	37	2
38	50	4
50	62	6

Inner heights



Inner widths



tsubaki-kabelschlepp.com/
tkp35

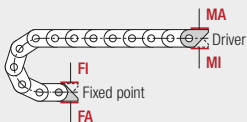

Connection point

F – fixed point
M – driver

Connection type

A – threaded joint outside (standard)
I – threaded joint inside

Order example



End connector	.	F	A
End connector	.	M	A
End connector		Connection point	Connection type